

**Installation and Operating Instructions for  
Cage Freewheels E**

**E 08.785**



**RINGSPANN GmbH**

Schaberweg 30-34  
61348 Bad Homburg  
Deutschland

Telefon +49 6172 275-0  
Telefax +49 6172 275-275

[www.ringspann.com](http://www.ringspann.com)  
[mailbox@ringspann.com](mailto:mailbox@ringspann.com)

<b>RINGSPANN GmbH</b>	<b>Installation and Operating Instructions for Cage Freewheels E</b>	<b>E 08.785</b>			
Stand: 05.05.2017	Version: 01	gez.: BRZA	gepr.: HEUT	Seitenzahl: 12	Seite: 2

---

## Important

Please read these instructions carefully before installing and operating the product. Your particular attention is drawn to the notes on safety.

These installation and operating instructions are valid on condition that the product meets the selection criteria for its proper use. Selection and design of the product is not the subject of these installation and operating instructions.

Disregarding or misinterpreting these installation and operating instructions invalidates any product liability or warranty by RINGSPANN; the same applies if the product is taken apart or changed.

These installation and operating instructions should be kept in a safe place and should accompany the product if it is passed on to others – either on its own or as part of a machine – to make it accessible to the user.

---

## Safety Notice

- Installation and operation of this product should only be carried out by skilled personnel.
- Repairs may only be carried out by the manufacturer or accredited RINGSPANN agents.
- If a malfunction is indicated, the product or the machine into which it is installed, should be stopped immediately and either RINGSPANN or an accredited RINGSPANN agent should be informed.
- Switch off the power supply before commencing work on electrical components.
- Rotating machine elements must be protected by the purchaser to prevent accidental contact.
- Supplies abroad are subject to the safety laws prevailing in those countries.

**This is a translation of the German original version!**

In case of inconsistencies between the German and English version of this installation and operating instruction, the German version shall prevail.

<b>RINGSPANN GmbH</b>	<b>Installation and Operating Instructions for Cage Freewheels E</b>	<b>E 08.785</b>			
Stand: 05.05.2017	Version: 01	gez.: BRZA	gepr.: HEUT	Seitenzahl: 12	Seite: 3

## Contents

1	General information .....	4
1.1	Application as a backstop .....	4
1.2	Application as an overrunning clutch.....	4
1.3	Application as an indexing freewheel .....	4
2	Design .....	5
3	Construction types .....	5
3.1	Standard type .....	5
4	General notes .....	6
5	Condition as delivered .....	7
6	Technical prerequisite for reliable operation.....	7
7	Installation .....	8
7.1	Assembly .....	8
7.2	Disassembly .....	8
7.3	Check the run out (T.I.R.) .....	8
8	Inspection before commissioning .....	10
9	Maintenance .....	10
10	Lubrication .....	11

<b>RINGSPANN GmbH</b>	<b>Installation and Operating Instructions for Cage Freewheels E</b>	<b>E 08.785</b>			
Stand: 05.05.2017	Version: 01	gez.: BRZA	gepr.: HEUT	Seitenzahl: 12	Seite: 4

## 1 General information

RINGSPANN Cage Freewheels E are machine elements that have specific characteristics in connection with an outer and inner ring:

- In one direction of rotation there is no contact between the inner and outer ring; the freewheel is in freewheeling operation.
- In the other direction of rotation there is contact between the inner and outer ring; in this direction, it is possible to transmit high torque.

Cage freewheels E are used as:

- Backstops
- Overrunning clutches
- Indexing freewheels



### Important!

Freewheels can be used as safety components, it is therefore essential that these installation and operation instructions are followed carefully.

### 1.1 Application as a backstop

Freewheels are used as backstops if reverse rotation is to be prevented. In many machines and installations, for technical safety or functional reasons, it is necessary to ensure that you are working in just one specified direction of rotation. That is why there are legal stipulations requiring a mechanical safety device for the operation of, e.g. conveyor systems.

The normal operating mode of a backstop is freewheeling operation; the locking (torque transmission) is performed at zero speed. The immediate engagement of the clamping elements ensures the required high operating safety.

### 1.2 Application as an overrunning clutch

The overrunning clutch engages machines or machine parts and automatically interrupts their contact as soon as the drive part of the overrunning clutch is turned faster than the driving part. In many cases, this can replace a more expensive externally actuated clutch.

With the overrunning clutches the engagement takes place in the driving operation (torque transmission), while in freewheeling operation the torque transmission between the inner and outer ring is interrupted. In driving operation, the speeds of the inner and outer ring are equal, while in freewheeling operation they are different.

### 1.3 Application as an indexing freewheel

The Indexing freewheel transmits a back and forth motion into a stepped rotation (indexed feed). The RINGSPANN Indexing freewheel works precisely and quietly and enables an infinitely adjustable setting of the feed.

<b>RINGSPANN GmbH</b>	<b>Installation and Operating Instructions for Cage Freewheels E</b>	<b>E 08.785</b>		
Stand: 05.05.2017	Version: 01	gez.: BRZA	gepr.: HEUT	Seitenzahl: 12   Seite: 5

## 2 Design

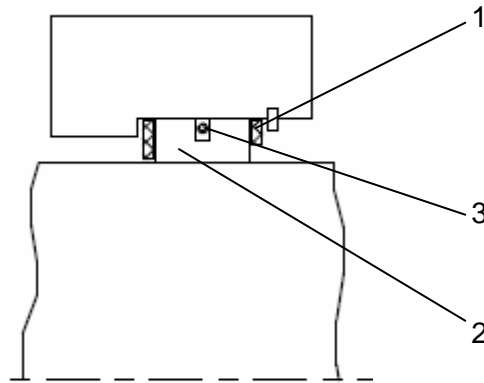

Figure [1] Sectional view of the cage freewheel and connecting parts

The cage freewheels E are designed in accordance with Figure 1. The most important functional parts are the cage (1), the sprags (2) and the springs (3).

E series cage freewheels are complete, ready-to-install units. The sprags are supported in a cage and worm spring-loaded.

## 3 Construction types

Cage freewheels SF are available in 1 type.

### 3.1 Standard type

This type is suitable for universal use.

Example: E 40-11/30



### Important!

More information, in particular on the design and function, layout and selection, permissible torques and permissible speeds of these freewheels, can be found in the RINGSPANN Data sheet. Alternatively, contact RINGSPANN GmbH directly.

<b>RINGSPANN GmbH</b>	<b>Installation and Operating Instructions for Cage Freewheels E</b>	<b>E 08.785</b>			
Stand: 05.05.2017	Version: 01	gez.: BRZA	gepr.: HEUT	Seitenzahl: 12	Seite: 6

#### 4 General notes



##### **Important!**

The safe torque transmission of the freewheel is only ensured if the maximum permissible driving speed is not exceeded.

**Exceeding the respective permissible speeds for the various operating states can lead to damage and an impermissible rise in temperature of the freewheel!**



##### **Important!**

The maximum permissible torque of the freewheel may not be exceeded by application-related peak torques.

The selection torque of the freewheel should be calculated with the help of the RINGSPANN catalogue 84, if necessary please contact RINGSPANN.

**Freewheel damages that result from impermissibly high peak torques lead to a loss of function and can lead to an impermissible rise in temperature of the freewheel!**



##### **Life-threatening danger!**

When using the freewheel as a backstop, ensure that it can only be removed, if required, when the facility is stationary without load.

**Removing the freewheel under load causes uncontrolled reverse rotation of the facility.**



##### **Important!**

No impermissible torsional oscillations (amplitudes and frequencies that lead to a loading and unloading of the freewheel in quick succession etc.) may occur.

**Torsional oscillations can lead to a loss of function and to an impermissible rise in temperature of the freewheel!**

<b>RINGSPANN GmbH</b>	<b>Installation and Operating Instructions for Cage Freewheels E</b>	<b>E 08.785</b>			
Stand: 05.05.2017	Version: 01	gez.: BRZA	gepr.: HEUT	Seitenzahl: 12	Seite: 7

## 5 Condition as delivered

The cage freewheels E series are corrosion protected and can, depending on the humidity, be stored in interior spaces in the original packaging for 6 to 12 months.

## 6 Technical prerequisite for reliable operation

The operationally reliable function of the cage freewheels is only ensured when:

- The customer's specified contact parts meet the requirements



### Important!

The transmissible torques apply in combination with the permissible run out (T.I.R.) between the shaft and the outer track in accordance with drawing or data sheet.

Compliance with the permissible run out (T.I.R.) must be ensured by the executed bearing and centring of the freewheel parts.

Ensure that the axial position of the cage freewheel, after connection, will be such that a free space is always provided between the cage and the front sides of the lateral guiding parts, see Figure [2].

The inner and outer sprag track of cage freewheels are manufactured by the customer. It must be hardened and machined (grinding or hard-turned). The sprag track must then have the following characteristics:

- Conicity:  $\leq 3 \mu\text{m}$  per 10 mm track width
- Average peak-to-valley depth Rz as per DIN 4768, page 1:  
 $1.6 \mu\text{m} \leq Rz \leq 6.3 \mu\text{m}$
- Hardness:  $62 \pm 2 \text{ HRc}$

With case hardening:

Case hardening depth Eht as per DIN 50190, page 1: 1,5 ... 2mm, hardness limit HG = 550 HV1, core strength  $\geq 1100 \text{ N/mm}^2$

Protection must be provided against contamination and moisture.

Depending on the operating data, oil or grease lubrication must be provided (see also Chapter 9 "Maintenance" and Chapter 10 "Lubrication").

<b>RINGSPANN GmbH</b>	<b>Installation and Operating Instructions for Cage Freewheels E</b>	<b>E 08.785</b>			
Stand: 05.05.2017	Version: 01	gez.: BRZA	gepr.: HEUT	Seitenzahl: 12	Seite: 8

## 7 Installation

### 7.1 Assembly

- Carefully clean the inner and outer track as well as the lateral guide parts (supplied by the customer) for the cage freewheel construction series E.
- Take the cage freewheel out of the packaging only immediately before assembly and check for contaminants and possible defects. In the event of contamination, the cage freewheel must be cleaned with a thin oil. A defective E construction series cage freewheel can only be repaired by the manufacturer. The cage freewheel is also defective when a sprag has fallen out.



#### **Important!**

Sprags that are falsely built into the cage will lead to functional disturbances and damages.

- Only install the cage freewheel in clean and dry surroundings.
- Check the direction of rotation of the machine or installation for the assembly of the cage freewheel.
- Install the cage freewheel into the outer ring under observation of the specified direction of rotation. The inner ring is subsequently pushed into the freewheel in freewheeling direction with a slight rotation.



#### **Important!**

Check the freewheeling direction of the machine after installing the freewheel by turning it lightly in freewheeling direction. If this does not correspond to the constructively designated freewheeling direction, the freewheeling direction can be changed by easily turning the cage freewheel construction series E or the entire freewheel unit around.

- The freewheel is to be completed with the remaining connection parts.

### 7.2 Disassembly

The disassembly is carried out analogously in reverse order to assembly.

### 7.3 Check the run out (T.I.R.)

The most reliable examination of the available run out (T.I.R.) of the outer and inner part between the shaft and the outer track can only be carried out in assembled state.

There are various methods of checking the run out (T.I.R.). In the following, one possibility is described.

- Fasten a dial gauge to the inner ring (1) and place the dial gauge sensor onto the track of the outer ring (2) (point U in Figure [2]).



- Turn the shaft slowly through 360° and hereby determine the maximum run out (T.I.R.). Ensure (in particular for sleeve bearing applications) that the bearing play is incorporated into the run out (T.I.R.).
- Compare this run out (T.I.R.) to the permissible value in accordance with the machine documentation.

The maximum run out (T.I.R.) can alternatively be determined by measuring the distance between the inner ring (1) and the outer track (2). The measurement should be carried out every 90° at the circumference with an internal measuring instrument, e.g. "Intertest". The largest difference of the measurement results lying in a line provides the run out (T.I.R.).

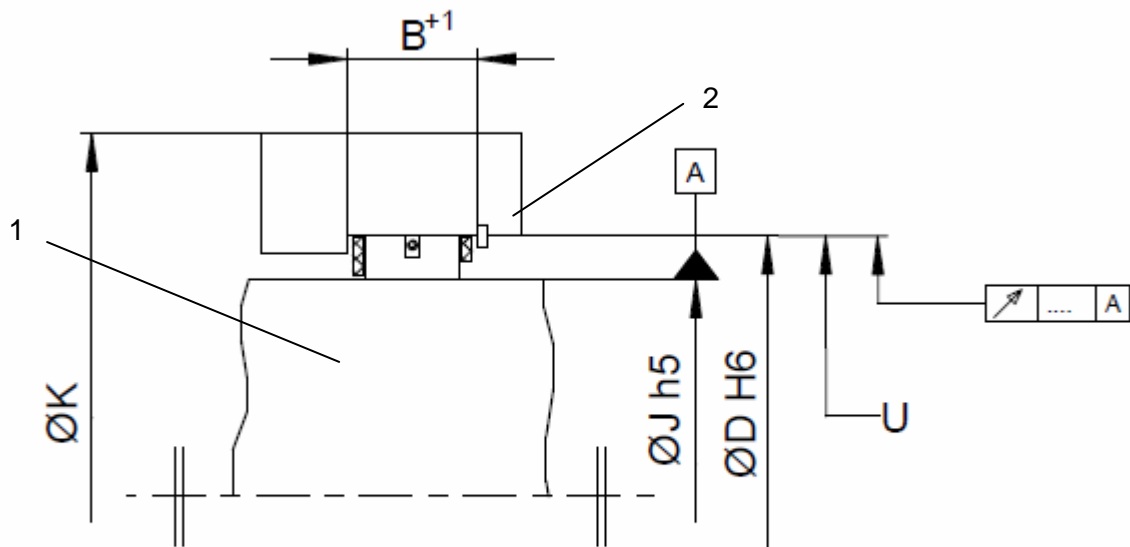

Figure [2] Measure the run out (T.I.R.) (example)

<b>RINGSPANN GmbH</b>	<b>Installation and Operating Instructions for Cage Freewheels E</b>	<b>E 08.785</b>			
Stand: 05.05.2017	Version: 01	gez.: BRZA	gepr.: HEUT	Seitenzahl: 12	Seite: 10

## 8 Inspection before commissioning

Check prior to commissioning that the shaft can be turned through evenly in the freewheeling direction of rotation (normal operating direction of rotation).

## 9 Maintenance

The first lubricant change is to be carried out after 10 hours of operation. Subsequent lubricant changes are to be carried out at the latest after 2000 hours of operation. If the cage freewheel E is provided with an external lubricant supply, for example from a gearbox, the lubricant change intervals of the external lubricant supply shall apply, these lubricant change times should however not significantly exceed the above times.

Before commissioning, the freewheel unit is to be filled with a suitable lubricant, the lubricant recommendations in accordance with Chapter 10 must hereby be observed.

- When using oil lubricant, the track of the inner ring should be dipped in oil.
- When using grease lubricant, the free space of the freewheel should be filled up by 30% to 40%.



### **Important!**

Too much grease can impair the function of the freewheel!  
Lubricants with graphite, Molykote or similar friction-reducing additives may not be used.

<b>RINGSPANN GmbH</b>	<b>Installation and Operating Instructions for Cage Freewheels E</b>	<b>E 08.785</b>
Stand: 05.05.2017	Version: 01	gez.: BRZA   gepr.: HEUT   Seitenzahl: 12   Seite: 11

## 10 Lubrication

When re-lubricating or changing the oil we recommend the following oil qualities:

Oil selection table			
Ambient temperature	For ambient temperatures from 0° to 50° C	For ambient temperatures from - 15° to + 15° C	For ambient temperatures from - 40° to 0° C
<b>Kinematic viscosity at 40° C, ISO-VG</b>	<b>46/68 [mm<sup>2</sup>/s]</b>	<b>32 [mm<sup>2</sup>/s]</b>	<b>10 [mm<sup>2</sup>/s]</b>
AGIP	OSO 46/68	OSO 32	OSO 10
ARAL	VITAM GF 46/68	VITAM GF 32	VITAM GF 10
BP	ENERGOL HLP 46/68	ENERGOL HLP 32	AERO HYDRAULIC 1
CASTROL	VARIO HDX	VARIO HDX	ALPHASYNTH 15
CHEVRON	EP HYDRAULIC OIL 46/68	EP HYDRAULIC OIL 32	HYJET IV
DEA	ASTRON HLP 46	ASTRON HLP 32	ASTRON HLP 10
ELF	ELFOLNA 46	ELFOLNA 32	ELF AVIATION HYDRAULIC OIL 20
ESSO	NUTO H 46/68	NUTO H 32	UNIVIS J 13
KLÜBER	LAMORA HLP 46/68	LAMORA HLP 32	Klüberoil 4 UH1-15
MOBIL	D.T.E. 25/26	D.T.E. 24	AERO HF A
SHELL	TELLUS OIL 46/68	TELLUS OIL 32	TELLUS OIL 10
Other manufacturers	Gear or hydraulic oils without solid lubricants ISO-VG 46/68	Gear or hydraulic oils without solid lubricants ISO-VG 32; Automatic transmission fluids [ATF]	Gear or hydraulic oils without solid lubricants ISO-VG 10; note setting point!  Aviation hydraulic oils ISO-VG 10

Please contact us in case of temperatures in excess of + 50° C and below - 40° C.

For grease lubrication, we recommend the following lubricants for ambient temperatures from – 15 °C to + 50 °C:

ARAL	ARALUB HL2
BP	ENERGREASE LS2
ESSO	BEACON 2
MOBIL	MOBILUX 2

KLÜBER	ISOFLEX LDS 18 Spezial A POLYLUB WH 2
SHELL	ALVANIA RL2